

Segmented Christmas Ornaments

By J. P. Davis

Making a Segmented Christmas ornament is a challenging and satisfying project for the intermediate wood turner. To make the ornament have a more visually appealing look, the ball can be made using 6 or a greater number of segments, utilizing this procedure. To make the segments stand out, a contrasting veneer will be used between them. For an alternate look, different woods can be used for the segments with or without a veneer. One thing that needs to be noted is that different wood densities can make hollowing a challenge.

This is the way I do it.

First, I start with a Hard Maple board that has been planed on 2 sides and is approximately 13/16" thick or thicker. I try to find a board that is at least 6" or 7" wide and cut it to approximately 24" long. One edge needs to be straight so that will follow the saw fence without wobbling when being cut.

A six sided ornament requires 6 pieces, each cut with a 60° total angle so that when assembled will make a complete circle. See Figure 1 below. Set your table saw so the blade is at a 30° tilt. Cut one side so that the blade leaves the edge being cut with a 30 degree bevel. Using the attached copy of my diameter and number of sides chart, select the row with 6 sides and select the diameter you want for the ornament ball. The chart starts with 3" diameter. In this case, I have chosen a 2-1/2" diameter ball and we will have to calculate the width of each side. If you select a 3" diameter or larger ball you can use the chart or you can calculate the width of each segment as follows: For a 6 sided figure with a Diameter of $2 \frac{1}{2}$ ", the Radius equals $1 \frac{1}{4}$ ". From the calculations shown in Figure 1, the widest part of the strip will be 1.443". This is equal to approximately $1 \frac{7}{16}$ ". When assembled with all six segments in place it will result in a ball $2 \frac{1}{2}$ " in diameter. See the calculations below for a six sided, $2 \frac{1}{2}$ " diameter ball.

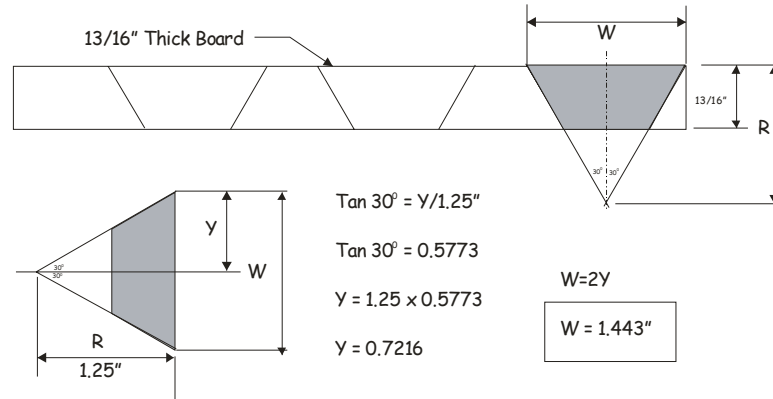

Figure 1.
Cutting the Segments

For the next cut, flip the board so that the beveled side is face down and the upper edge is against the saw fence. Measure the distance from the fence to inside edge of the saw blade teeth so that it will result in a strip that is 1 7/16" wide when cut. See Figures 2 and 3 showing how the board is to be cut. Cut as many pieces as you have board or boards available. You should end up with several pieces as shown in Figure 3.

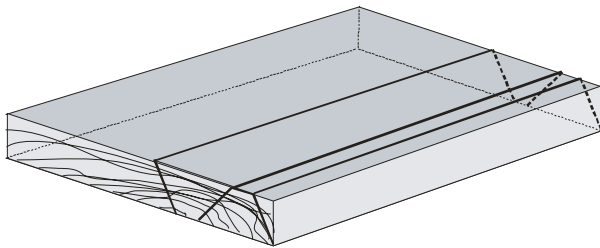

Figure 2.

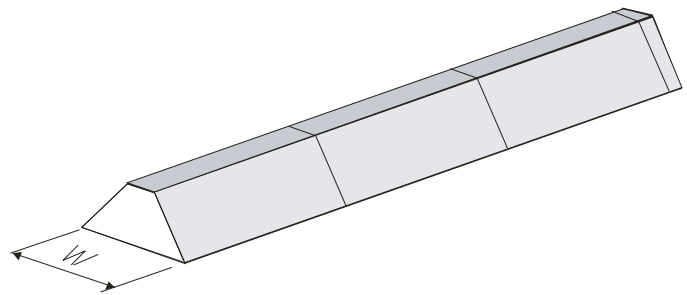

Figure 3.

Cut each of the long pieces shown in Figure 3 into smaller lengths of 2 1/2" long. You should be able to cut 9 pieces from each strip if you use 24" long wood. See Figure 4 showing the separate pieces.

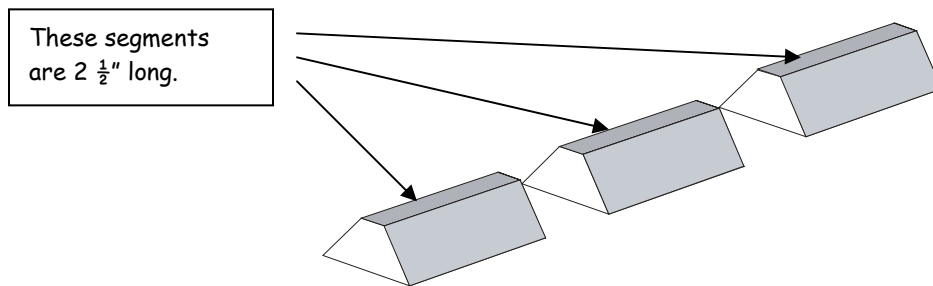

Figure 4.

To enhance the look of the ball, cut and install contrasting strips of 1" wide veneer 2 $\frac{1}{2}$ " long. Spread glue on the sloped sides of 2 pieces, insert the veneer and press the pieces together. Add the 3rd side in the same manner. Make 2, $\frac{1}{2}$ sub assemblies as shown in Figure 5. Wait to put veneer on the two $\frac{1}{2}$ assembly sides.

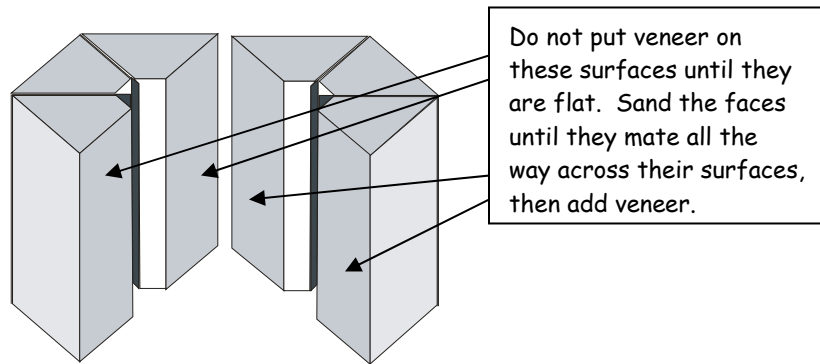

Figure 5.
 $\frac{1}{2}$ Sub Assemblies

After the glue joints have dried to the point where they won't come apart, hold both $\frac{1}{2}$ assemblies together and check to see the fit. If the two faces are not perfectly flat hold the flat faces of the two halves against a sander until the faces of the two $\frac{1}{2}$ Sub Assemblies fit with no gap. Spread glue on each face and add veneer strips and press both halves together. Wrap a rubber band around the pieces until they are dried. The resulting structure should look as that shown in Figure 6.

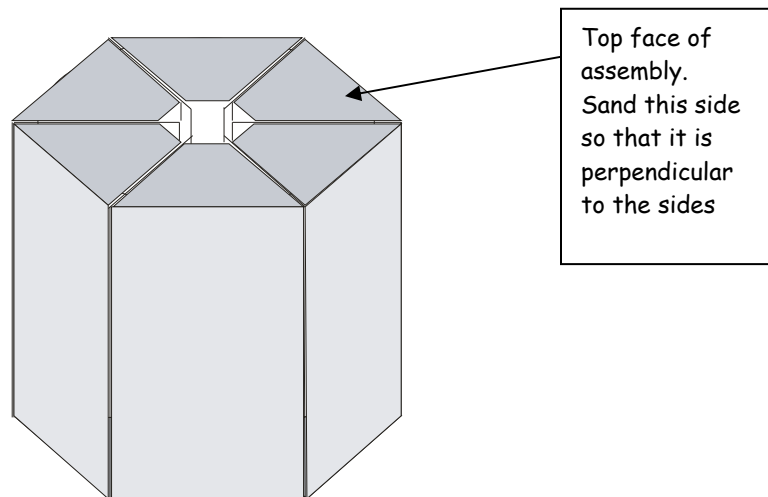

Figure 6.
Full Assembly

Sand a top face of the assembly so that it is perpendicular to the sides. This will keep the assembly true to the center line of the lathe. Add a sacrificial glue block to the sanded side as shown in Figure 7. Center the glue block on the top of the assembly.

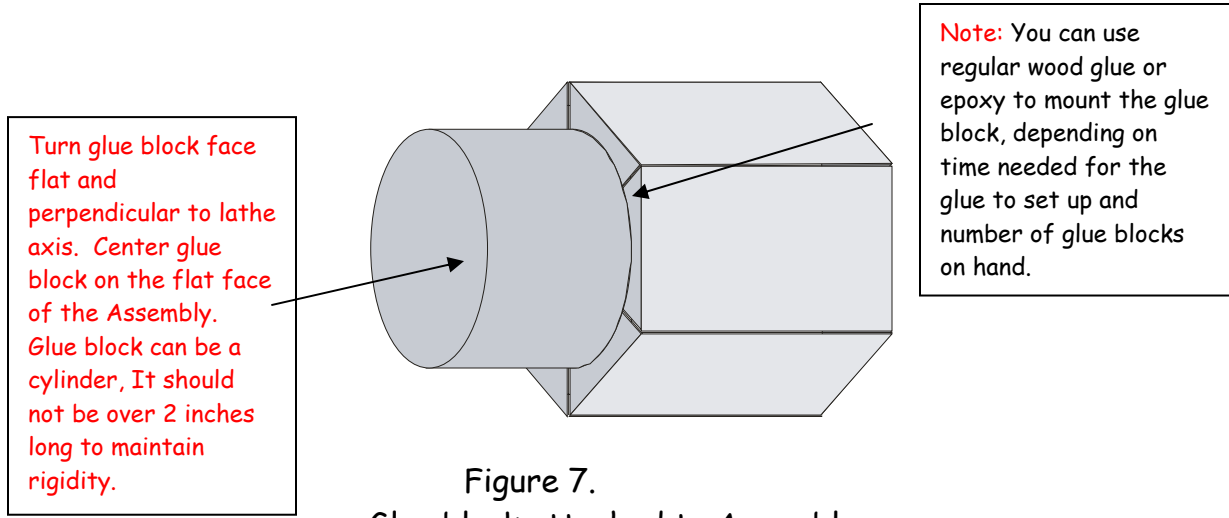

Figure 7.
Glue block attached to Assembly

Mount the glue block and assembly in your lathe. Install a 1" Fosner Drill in the Tail stock and drill out the inside of the segmented portion of the assembly. Drill out the assembly all the way to the glue block. A 1" hole will make hollowing the ball fairly easy.

Before hollowing, the next step is to shape the outside of the ball. Turn the segmented portion of the assembly so that it is round. In this ornament, the ball will be shorter along the axis and a larger diameter (squashed), it can be round or a long oval shaped whichever you want. Shape the ball as shown in Figure 8 below.

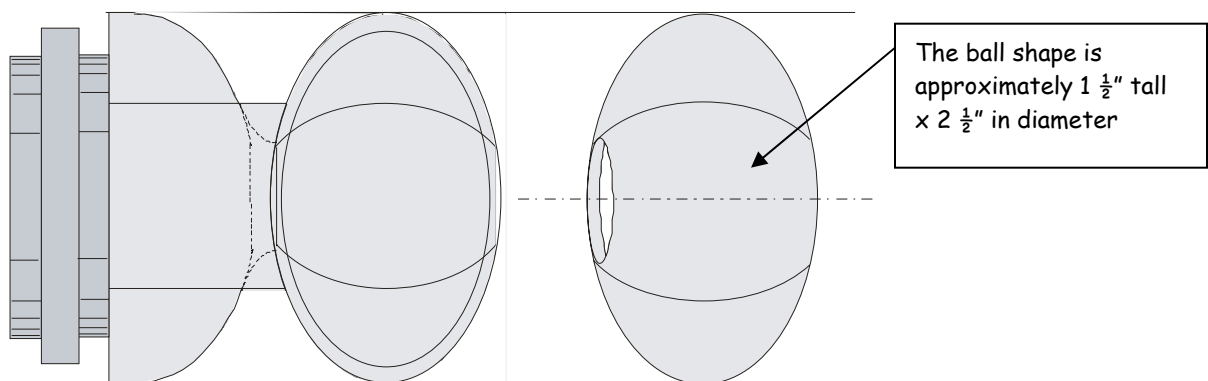

Figure 8.

When the ball outer shape has been partially formed, begin hollowing so that it has a 3/16" to 1/8" wall thickness (be careful not to cut the ball off before hollowing). The inside wall should be parallel the outer surface. Prior to cutting the ball off, sand the outer surface until it shows no scratches. After the ball has been hollowed and sanded to your satisfaction cut, off the ball. For this project, it should have a shape similar to the one shown in Figure 8.

You are almost there, just a few more steps.

The next item is to make 2 bushings. Each bushing has a 1" tennon on the concave side with a 1/2" hole drilled in the center of the bushing. The other side has a convex shape. To make the bushing, glue or epoxy a dark or contrasting piece of wood that is approximately 2" x 2" x 3/8" to 1/2" thick to a glue block. Mounting and shaping the bushing on a glue block will allow cutting and shaping it much easier. See Figure 9 below.

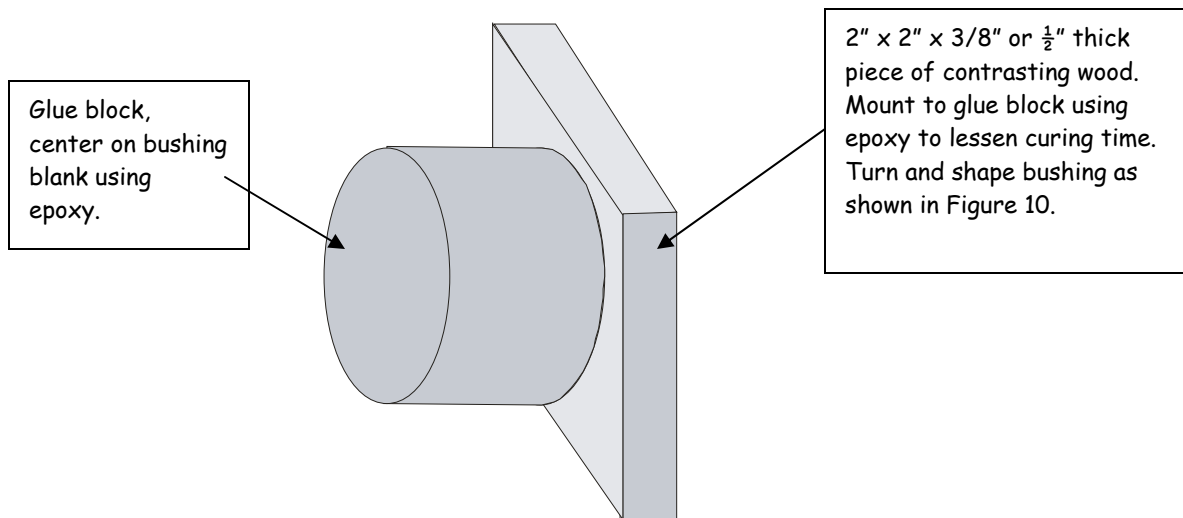
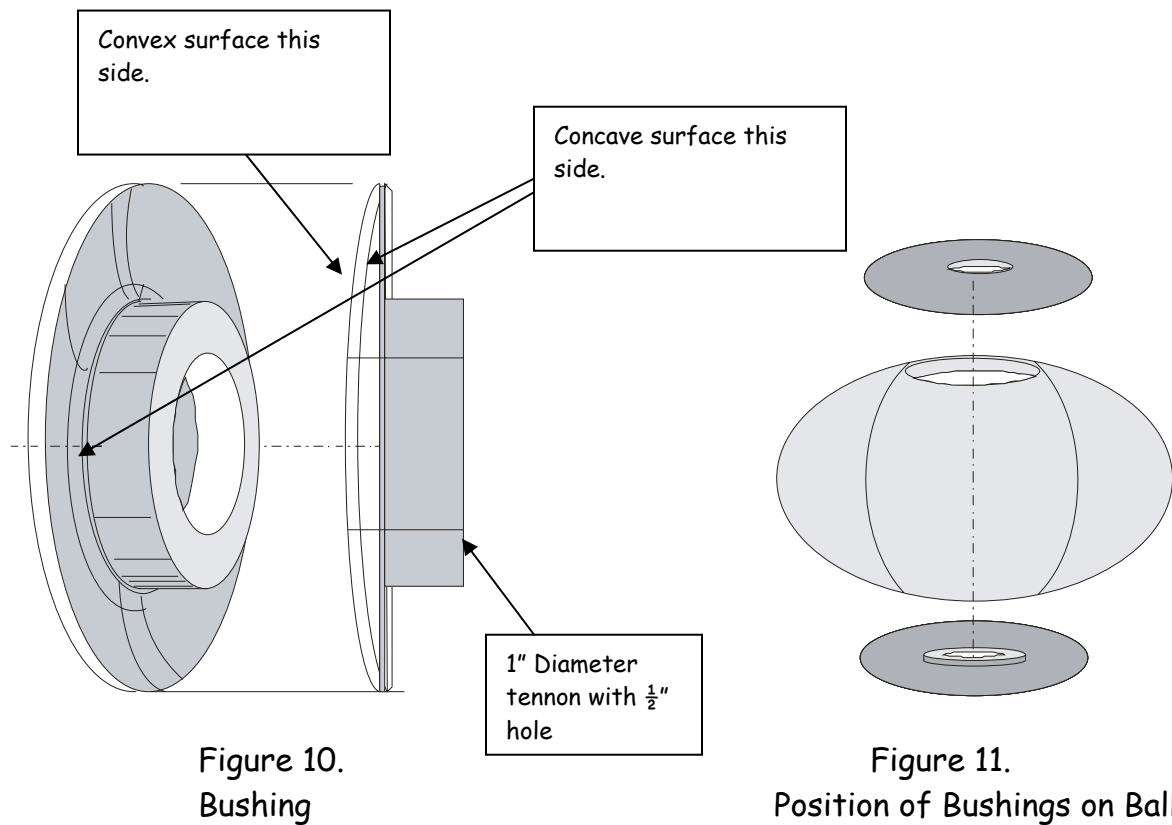

Figure 9.
Mounting of bushing blank to glue block.

Two bushings are required, one for the top and one for the bottom. Make the bushings from a wood that will contrast to the Maple Ball. I used cocobolo and black palm for the bushings. The tennon on the concave side of the bushing should have a snap fit, as it is set into the hole of the ball; and are installed as shown in Figure 11.



We are ready to make the final parts.

The final part of this project is making the upper and lower finials. I use a dark wood such as East Indian Rose Wood or Ebony for these. Since the holes in the bushings are $\frac{1}{2}$ inch in diameter a $\frac{3}{4}$ " pen blank will work really well as a finial. I use a wood that will contrast with the ball and bushings. There are many $\frac{3}{4}$ " pen blanks available that will work just fine.

This year's Christmas ornament has a long finial on top and the short one on bottom. If your preference is a short finial on top and a long one on the bottom the ball can easily be inverted and the hanging ring installed on that finial.

The top finial is formed from ebony and shaped as shown in Figure 12 below. The base of the finials all have a $\frac{1}{2}$ " diameter tenon on them. The top finial is approximately 3 to 3 $\frac{1}{2}$ " long. Sizing a $\frac{1}{2}$ " tenon can be made easy if you sharpen an old 1/2 " open end wrench and use it as the cutting tool.

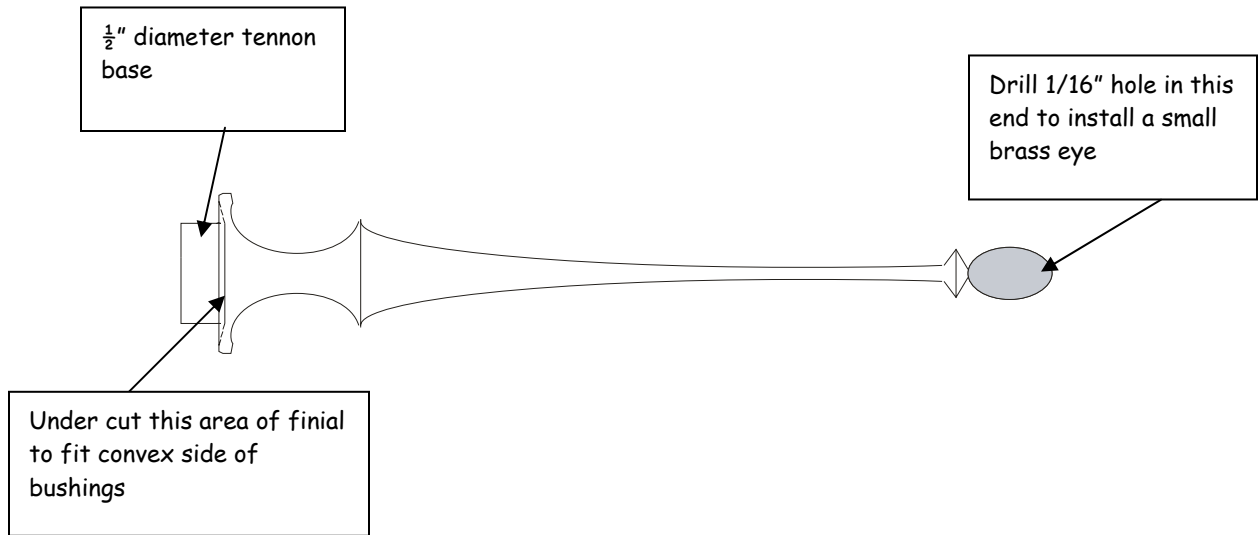

Figure 12.
Top Finial- 3" to 3 $\frac{1}{2}$ " long

The bottom finial is also made from a dark wood and in this project it is either East Indian Rose Wood or Ebony or is the same type wood as the top finial. The bottom finial is similar in shape to the top finial, but is shorter and represented in Figure 13. The bottom finial is 2 to 2 $\frac{1}{2}$ " long. Both finials have a $\frac{1}{2}$ " diameter tennon that fits the $\frac{1}{2}$ " hole in the top and bottom bushings.

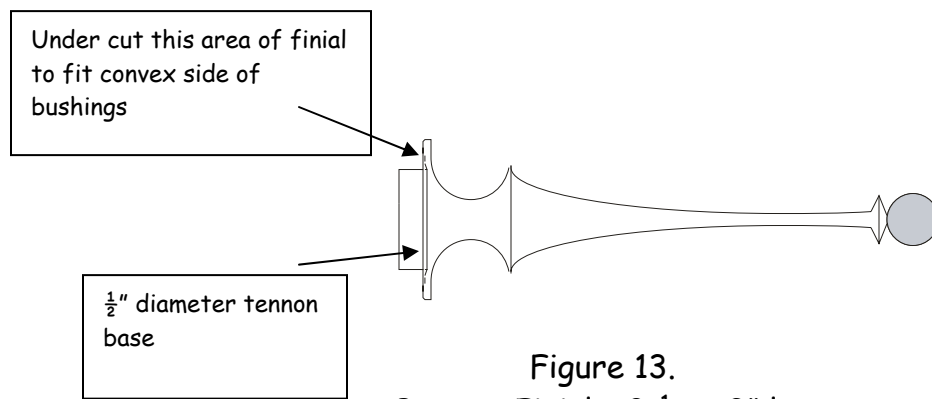

Figure 13.
Bottom Finial - 2 $\frac{1}{2}$ to 3" long

Now that all parts have been made we are ready to assemble the Christmas Ornament.

Install the top finial in one of the bushings on the convex side of the bushing and glue together. I use Titebond II, thin super glue or epoxy depending on the fit to attach all of the parts.

Assemble the bottom finial in the other bushing in the same manner and glue together. The next step is to glue the top and bottom finial and bushing sub assemblies into the 1" diameter hole in the ball.

The Christmas ornament, if each part is made correctly, should look similar to the ornament shown in Figure 14.

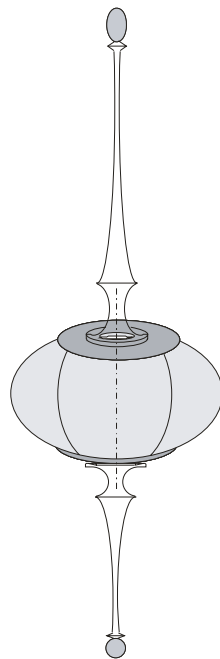

Figure 14.
Assembled Christmas Ornament

After assembly I spray each ornament with several coats of lacquer sanding with 400 grit or higher sand paper between coats.

Each year I make a different ornament for my grandchildren and great nephews and nieces. I put their name, my name and the year on the bottom of the ornament using a paint pen. I always include a separate piece of paper describing the materials used in making the ornament.

This is an heirloom they can pass on to their children. One good thing is that there is no glass involved to get cut.

Have a Very Merry Christmas 2008

All drawings, charts and descriptions used in this project are property of J. P. Davis